

HONGSAM®

HONG-JET®

Shift to Green

No Powder DTF Printing Solution



HJ-603



Zhengzhou Hongsam Digital Science and Technology Co., Ltd.

Phone: +86-371-60301017/60301018

Email: dctec@ink4you.com

Website: www.hongsam.cn



Whatsapp



Facebook



Youtube

Process Features:

- **Digital customization:** digital transferring process, no plate, no engraving, short process, personalized, immediately available.
- **Environmental friendly:** water-based environmentally friendly DTF ink, bright color and non-fading, pollution-free production process, guaranteed product safety.
- **Features:** unique CO ink, design, printing, transferring at one time, no powder, saving process and material costs.
- **Return to the original:** suitable for various fabrics, leathers, coil plates, does not affect the texture and feel of the original material.
- **Color fastness:** high textile printing color fastness, high resistance to scratching and bending, good air permeability, high weather resistance, hydrolysis resistance.
- **Reasonable structure:** the printer and dryer are light in design and compact in structure, saving floor space.
- **Intelligent drying:** intelligent temperature-controlled hot air circulation system, effective use of heat circulation, save power consumption.
- **Intelligent purification:** standard patent smoke exhaust system, effectively remove internal moisture, ensure drying effect, small size, low noise.

Process Flow:

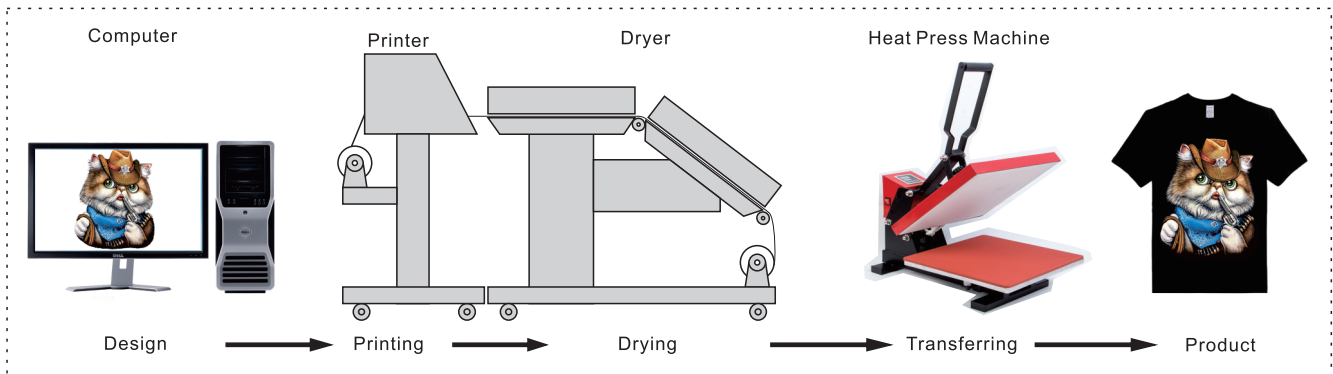

Printing Principle:

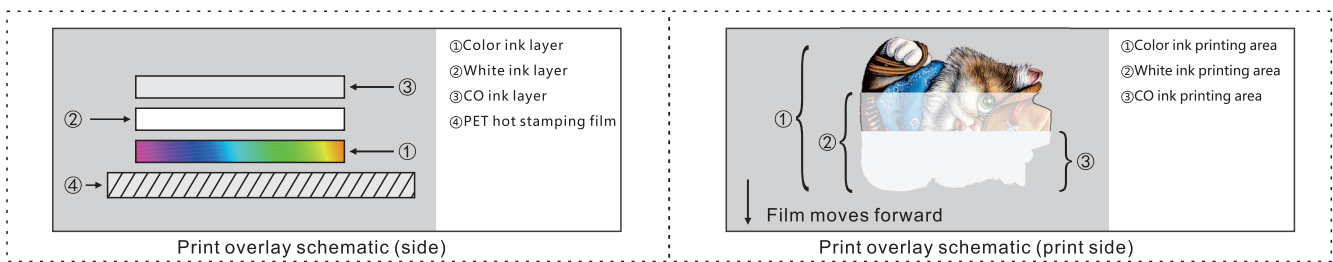

Parameter specifications:

Printer				Dryer			
Model	HJ-603			Model	HJ-H60		
Print head	Epson i3200-A1			Drying mode	Intelligent temperature controlled hot air circulation drying system + front guide plate drying system		
Printhead No.	3-4			Temperature range	150□		
Ink type	Water-based eco-friendly dtf ink			Drying tunnel Length and Width	W:730mm, L:580mm*2		
Color	KCMY+W+CO,KCMY+W+CO+CO			Drying tunnel Height	25mm		
Printing capacity*	Economy mode	4pass	12m ² /h	Loading system	Dual power motor adjustable damping paper stacker		
	Production mode	6pass	10m ² /h	Power	AC220V 50/60Hz 16A	maximum power	5.8 kW
	Quality mode	8pass	6m ² /h			working power	2.4 kW
Printing format	600mm			Equipment dimension and weight*			
Printing media	PET film			Working area	L×W	2800*3500mm	
Ink supplying	Big capacity continuous ink supplying system, low liquid level alarm				Printer	L×W×H	1980*1050*1550mm
White ink system	Intelligent automatic circulation mixing system			Dryer		Weight	142KG
Print head protection	Intelligent dual side high sensitivity anti scratch system				L×W×H	1460*1100*1200mm	
Printing height	Manual knob adjustable			Weight		160KG	
RIP software	RIIN,MainTop,PhotoPrint				Shipping dimensions and weight*		
Printing software	PrintExp			Printer	L×W×H	2160*1160*880mm	
Operating system	Win7 64-bit,Win10 64-bit				Dryer	Weight	191KG
Interface	kMbps network			L×W×H		Machine dimension:1520*1160*1360mm	
Power	AC220V 50/60Hz 10A,maximum power: 1.2kW				L×W×H	Package dimension:1880*900*585mm	
Working environment	temperature:20°C-30°C humidity:35%-65%			Weight		210KG	

*For reference only